

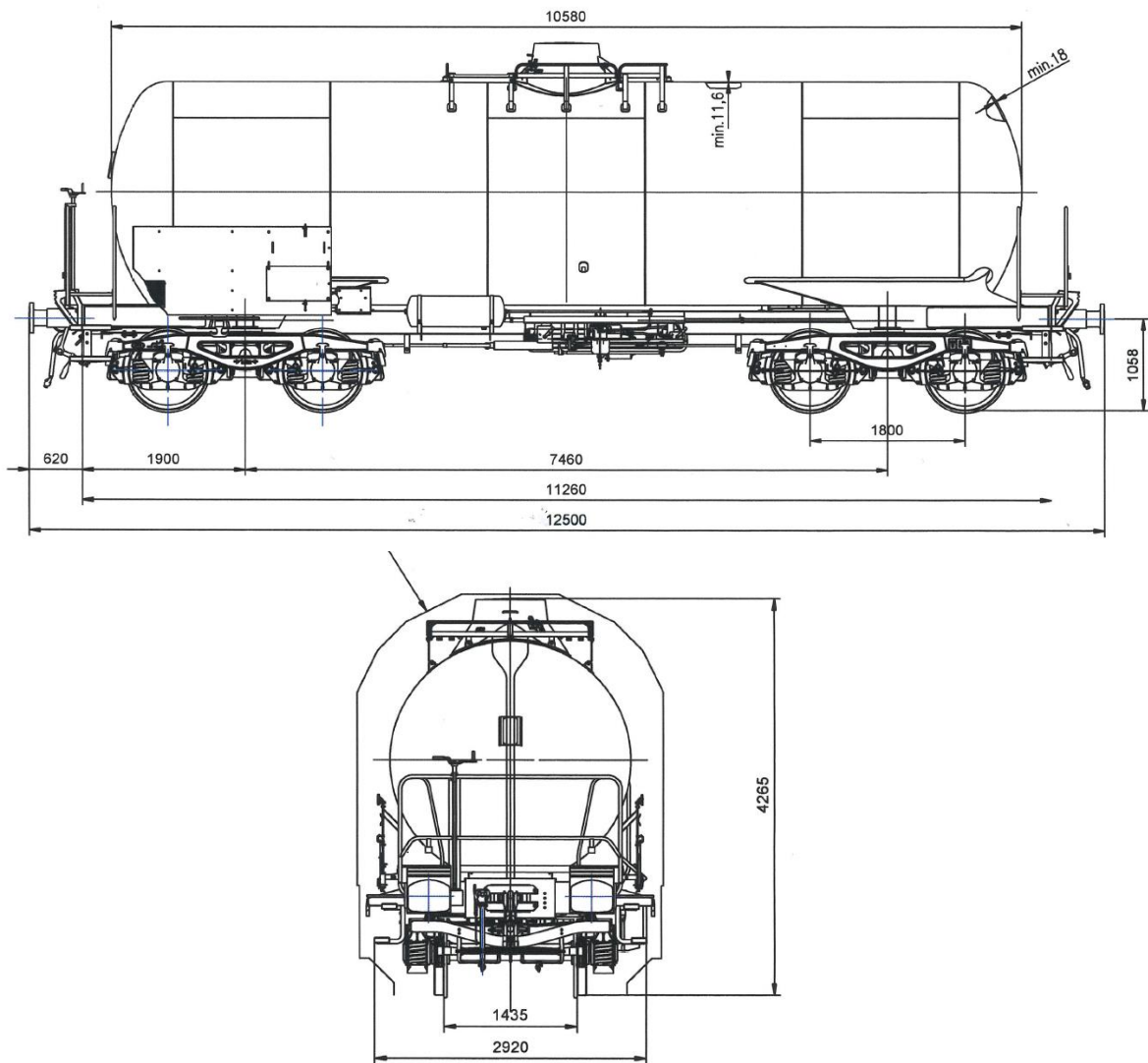

**Wagon chlore / Chlorine wagon –
90T 52.2m³**



CARACTERISTIQUES GENERALES / GENERAL CHARACTERISTICS:

- MASSE TOTALE SUR RAILS / WEIGHT ON RAIL: **90T**
- TARE / TARA: ≈ **24.9T**
- CHARGE D / D-LOAD: ≈ **65.1T**
- CHARGE C / C-LOAD: ≈ **57.1T**
- CAPACITE TOTALE / TOTAL CAPACITY: ≈ **52.2m³**
- CODE CITERNE / TANK CODE : **P22DH**